

# 6SC3433VGB00MSZ9 Datasheet

3433 Series (L\* W\*H): 3.4\*3.3\*1.9mm



## Applications

-  Automotive interior light

## Features

-  Forward current:  $\leq 50\text{mA}$  ;
-  Typical view angle 50% Iv:  $120^\circ$
-  Qualified according to JEDEC moisture sensitivity Level 2a
-  Lens color: White diffused
-  RoHS2.0 and REACH-compliant
-  ESD level 2kV(HBM)
-  Reliability Test: AEC Q-102qualified

# 6SC3433VGB00MSZ9

## Dimensional Drawing

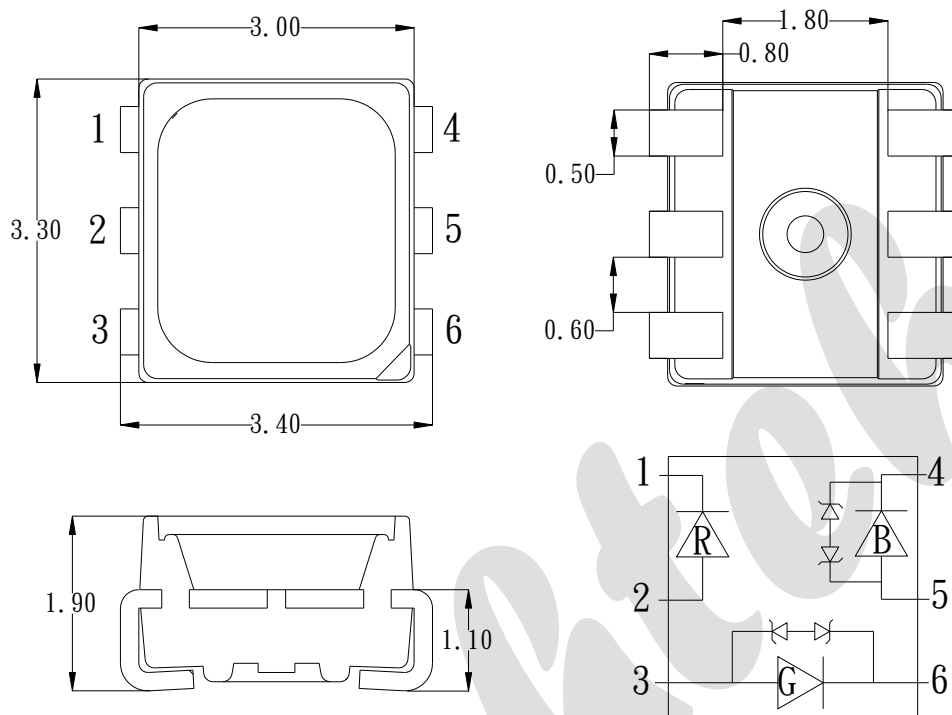

### Recommend Pad layout

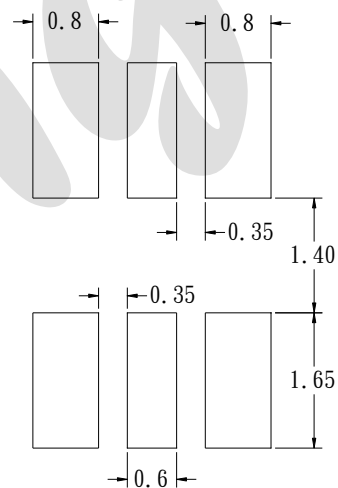

1. Dimensions are in millimeters.
2. General tolerance is  $\pm 0.1\text{mm}$ .

# 6SC3433VGB00MSZ9

## Naming Rule

### 6-S-C-3433-VGB0-0-M-S-Z9

6	S	C	3433	
Customer Code	Color	Package Type	Package Size	
6 : special product	S: SMD LED	C: PLCC top view D: PLCC side view	3433: 3.4* 3.3mm	
VGB0	0	M	S	Z9
Wavelength	Lap Polarity	Package Color	PCB Module Code	Serial Number
V:red/G:green/B:blue	0: non-common anode and non-common cathode	M: white diffused	S: article mode	Z:zener 9: no expression above meaning for company

## Maximum Ratings

T<sub>A</sub> : 25 °C

Characteristics	Symbol	Typical	Unit
DC Forward Current	IF	50	mA
Pulse Forward Current*3	IPF	100	mA
Reverse Voltage	VR	5	V
Junction Temperature	TJ	125	°C
Operating Temperature Range	TOP	-40-105	°C
Storage Temperature Range	TSTG	-40-105	°C
Soldering Temperature*4	TSD	260	°C
Thermal Resistance Junction/ Solder Point	RTHJ-S	60	°C/W
Thermal Resistance Junction/Ambient Point	RTHJ-A	120	°C/W

1. There is no maximum or typical voltage parameter.
2. For other ambient, limited setting of current will be depended on de-rating curves.
3. Duty 1/10, pulse width 0.1ms.
4. The maximum of soldering time is 10 seconds in T<sub>SD</sub>.

# 6SC3433VGB00MSZ9

## Characteristics

IF : 20mA | TA : 25 °C

Characteristics	Symbol	Min.	Typ.	Max.	Unit	Test condition	
Forward Voltage	VF	V	1.8	-	2.6	V	IF=20mA
		G	2.6	-	3.4		
		B	2.6	-	3.4		
Reverse Current	IR	-	-	10	μA	VR= 5V	
Luminous Intensity	Iv	V	550	680	850	mcd	IF=20mA
		G	2150	2660	3350		
		B	200	280	350		
Dominant Wavelength	λd	V	630	-	636	nm	IF=20mA
		G	520	-	525		
		B	450	-	455		
View Angle	2θ1/2	-	120	-	deg	IF=20mA	

### 1. Tolerance of Measure:

Forward Voltage: ±0.1V, Luminous Intensity: ±10%*mcd*, Dominant Wavelength: ±1.0*nm*

# 6SC3433VGB00MSZ9

## Bin groups

### 1. Luminous Intensity (IF=20mA)

Bin code		Min. Iv (mcd)	Max. Iv (mcd)
V	1	550	680
	2	680	850
G	1	2150	2660
	2	2660	3350
B	1	200	280
	2	280	350

### 2. Forward Voltage (IF=20mA)

Bin Code		Min. Vf (v)	Max. Vf (v)
V	A	1.8	2.6
G	B	2.6	3.4
B	C	2.6	3.4

### 3. Dominant Wavelength Bins (IF=20mA)

Bin Code		Min. $\lambda_d$ (nm)	Max. $\lambda_d$ (nm)
V	A	630	636
G	B	520	525
B	C	450	455

# 6SC3433VGB00MSZ9

## 4. Chromaticity Coordinate Groups ( IF=20mA )



Bin	X	Y	X	Y	X	Y	X	Y
R30	0.7043	0.2924	0.7079	0.292	0.7151	0.2848	0.7113	0.2852
G20	0.1461	0.7528	0.1708	0.6963	0.1535	0.6781	0.1239	0.7361
B50	0.1597	0.0233	0.1552	0.03	0.1513	0.0232	0.1566	0.0177

Tolerance of X/Y :  $\pm 0.005$

# 6SC3433VGB00MSZ9

## Relative Spectral Power Distribution

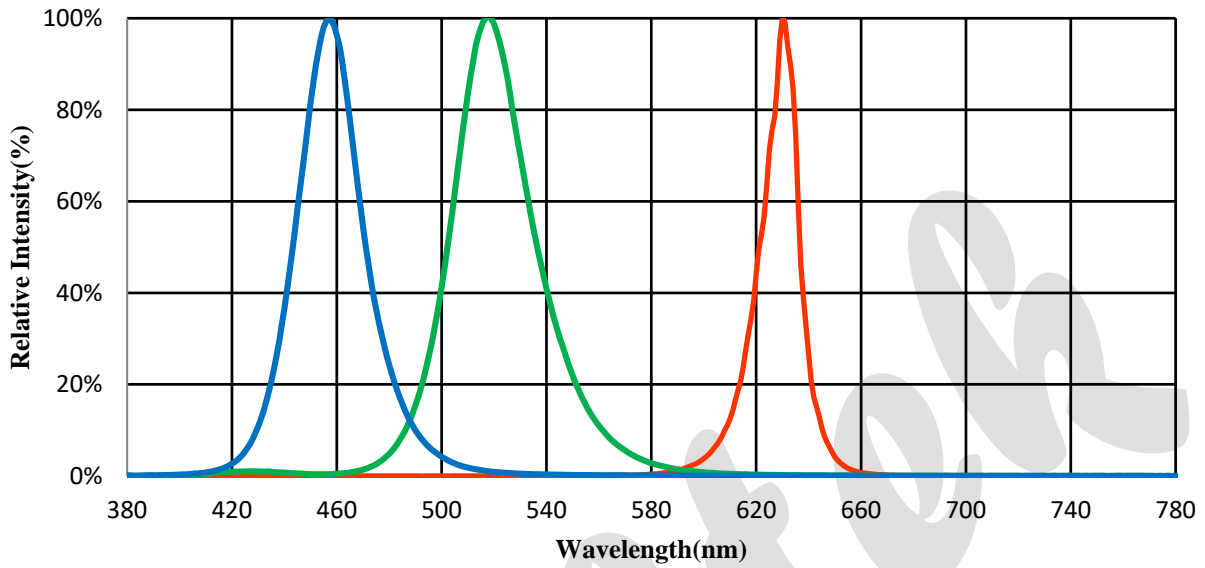

## Typical Diagram Characteristics of Radiation

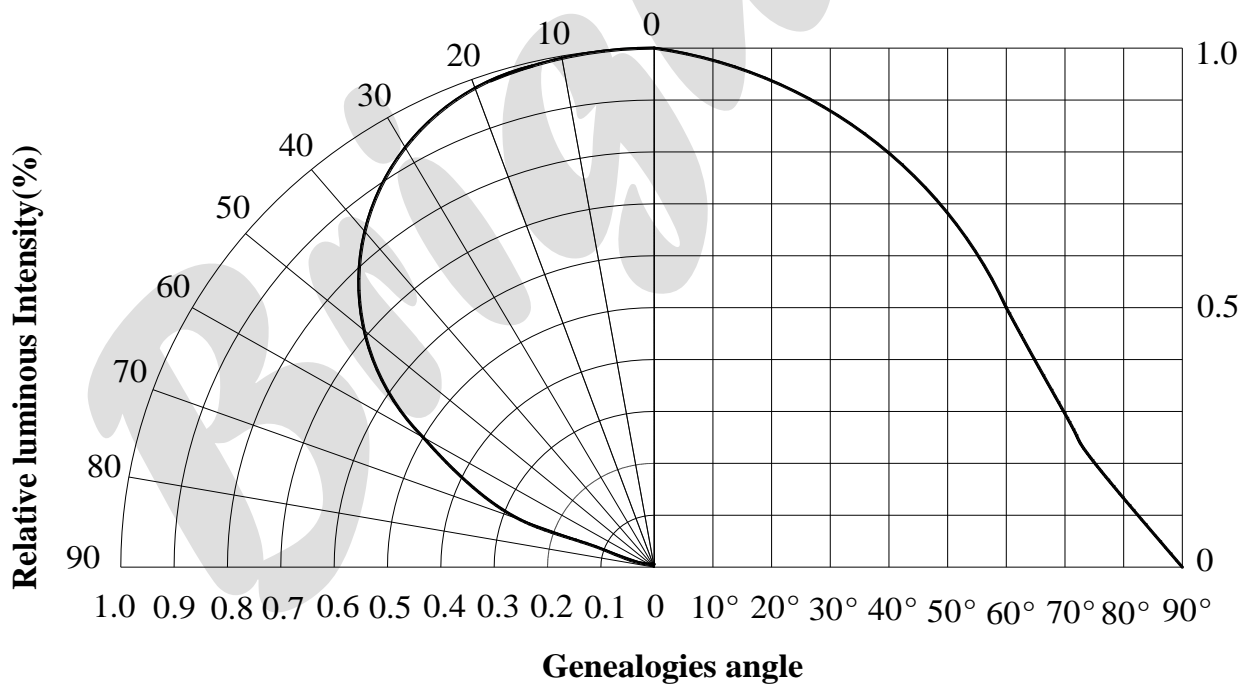

# 6SC3433VGB00MSZ9

## Electronic-Optical Characteristics

Relative Forward Current vs. Forward Voltage Temperature

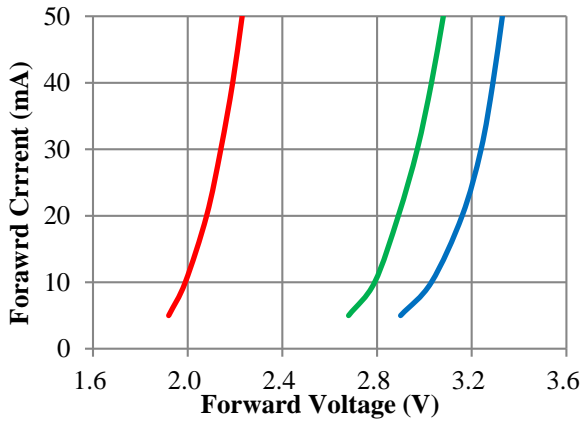

Relative Forward Voltage vs. Temperature

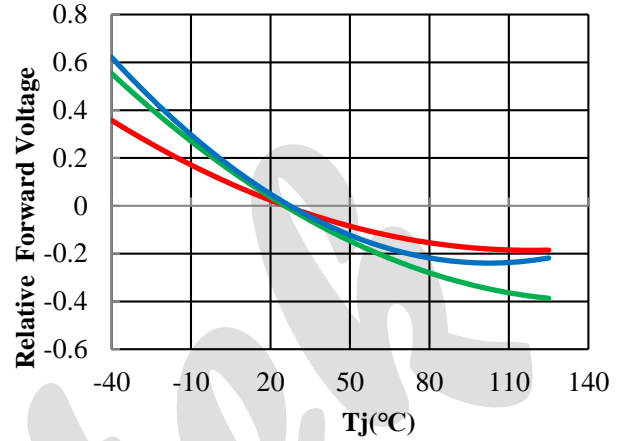

Relative Intensity vs. Forward Current

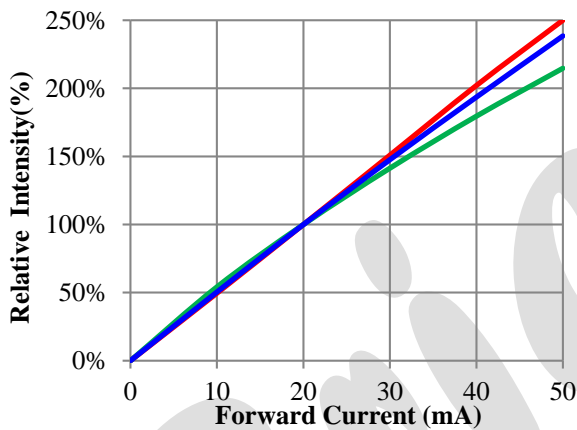

Relative Intensity vs. Temperature

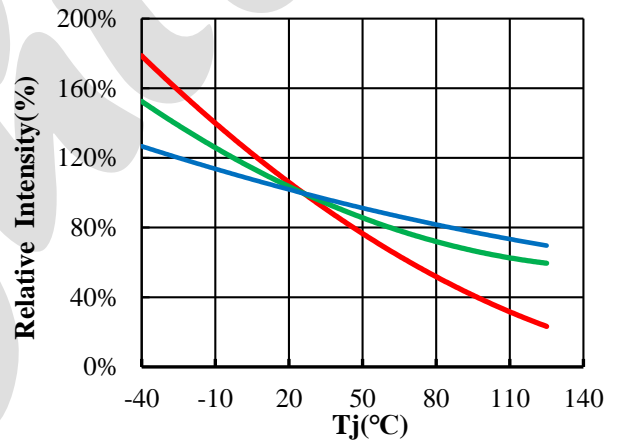

Wavelength shift vs. Forward Current

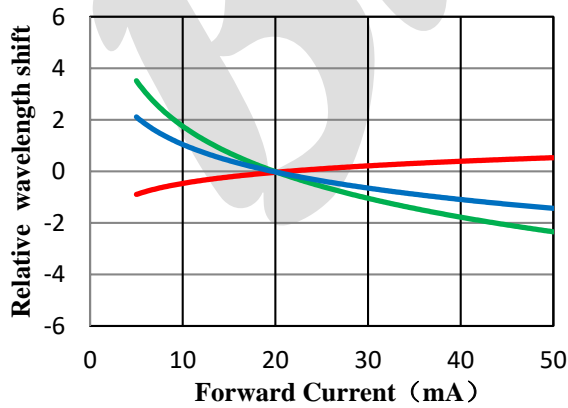

Wavelength shift vs. Temperature

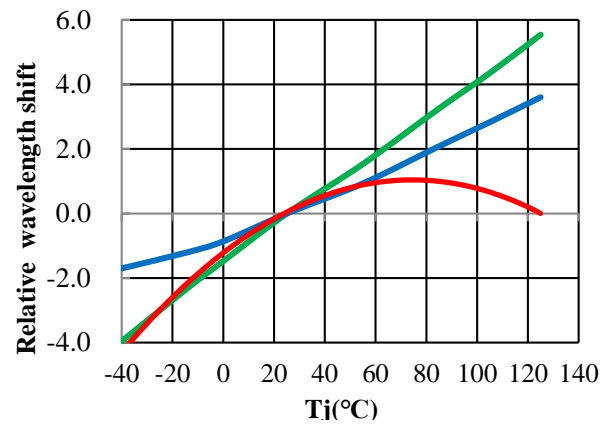



# 6SC3433VGB00MSZ9

## Reflow Soldering Profile

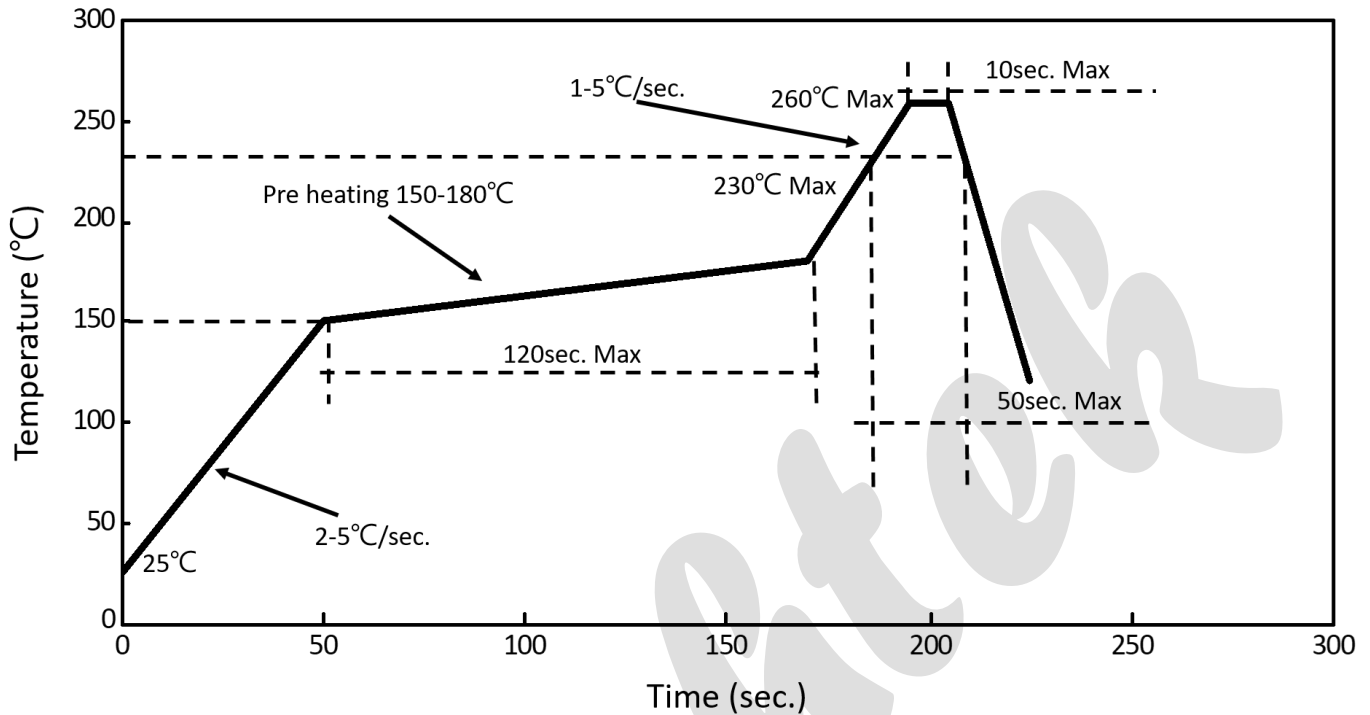

Characteristics	Symbol	Pb-Free (SnAgCu) Assembly			Unit
		Min.	Recommendation	Max.	
Ramp-up rate to preheat (25°C to 150°C)	-	-	2	3	K/s
Time tS (TS min to TS max)	tS	60	100	120	s
Ramp-up rate to peak (TS max to TP)	-	-	2	3	K/s
Liquidus temperature	TL	-	217	-	°C
Time above liquidus temperature	tL	-	80	100	s
Peak temperature	TP	-	245	260	°C
Time within 5 °C of the specified peak temperature TP - 5 K	tP	-	-	10	s
Ramp-down Rate (TP to 100 °C)	-	-	3	4	K/s
Time 25 °C to TP	-	-	-	480	s

1. We recommend the reflow temperature 240°C (±5°C).the maximum soldering temperature should be limited to 260°C.
2. Do not stress the silicone resin while it is exposed to high temperature.
3. The reflow process should not exceed 3 times.

## Test Circuit and Handling Precautions

### 1. Test circuit

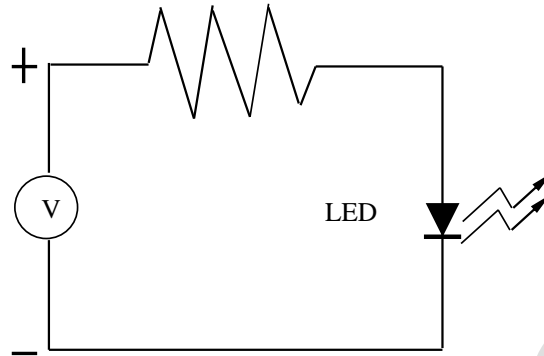

### 2. Handling precautions

#### 2.1 Over-current-proof

Customer must apply resistors for protection; otherwise slight voltage shift will cause big current change (Burn out will happen).

#### 2.2 Storage

① It is recommended to store the products in the following conditions:

- Humidity: 60% R.H. Max.
- Temperature :  $5^{\circ}\text{C} \sim 30^{\circ}\text{C}$  ( $41^{\circ}\text{F} \sim 86^{\circ}\text{F}$ )

② Shelf life in sealed bag: 12 month at  $< 5^{\circ}\text{C} \sim 30^{\circ}\text{C}$  and  $< 60\%$  R.H. after the package is Opened, the products should be used within 4 weeks or they should be keeping to storage at  $\leq 20\%$  R.H. with zip-lock sealed.

#### 2.3 Baking

Suggest packing open after 4 weeks, before use baking products, conditions as follows:

- ①  $60 \pm 3^{\circ}\text{C}$  X 6hrs and  $< 5\%$  RH, for reel
- ②  $125 \pm 3^{\circ}\text{C}$  X 2hrs, for single LED

It shall be normal to see slight color fading of carrier (light yellow) after baking in process.

# 6SC3433VGB00MSZ9

## Tapping

### 1. Dimensions of Tape (Unit: mm)

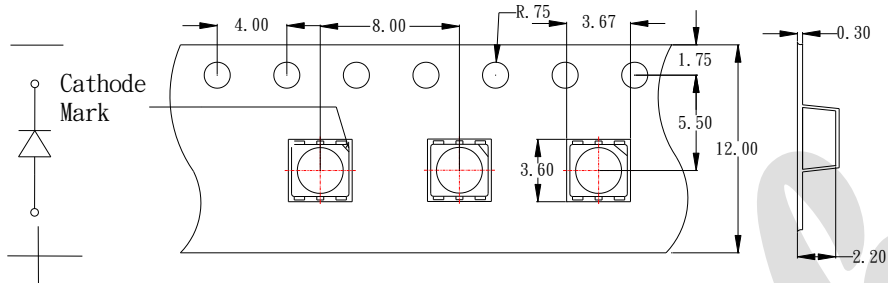

### 2. Arrangement of Tape

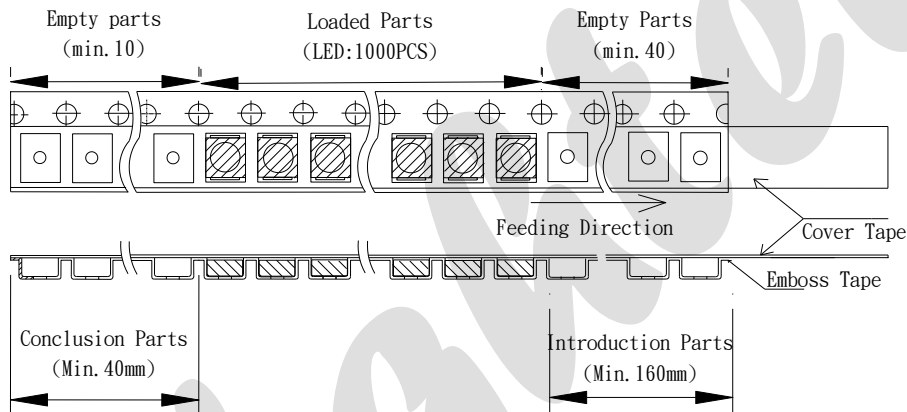

### 3. Dimensions of Reel (Unit: mm)

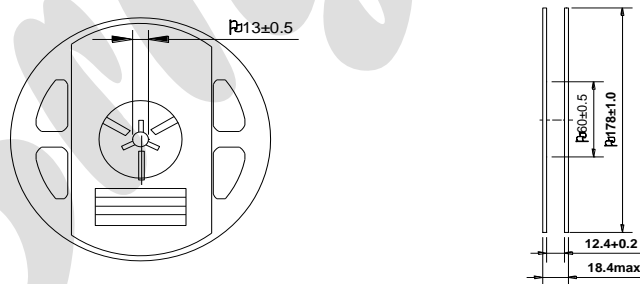

Note: 01. The tolerance unless mentioned is  $\pm 0.1 \text{ mm}$ .  
02. The measured unit is "mm".

### Notes:

1. Empty component pockets are sealed with top cover tape
2. The max loss number of SMD is 2pcs
3. The cathode is oriented towards the tape sprocket hole in accordance with ANSI/EIA RS-481 specifications
4. 1,000pcs per reel
5. The remainder packing in multiples of 500pcs.

# 6SC3433VGB00MSZ9

## Packing

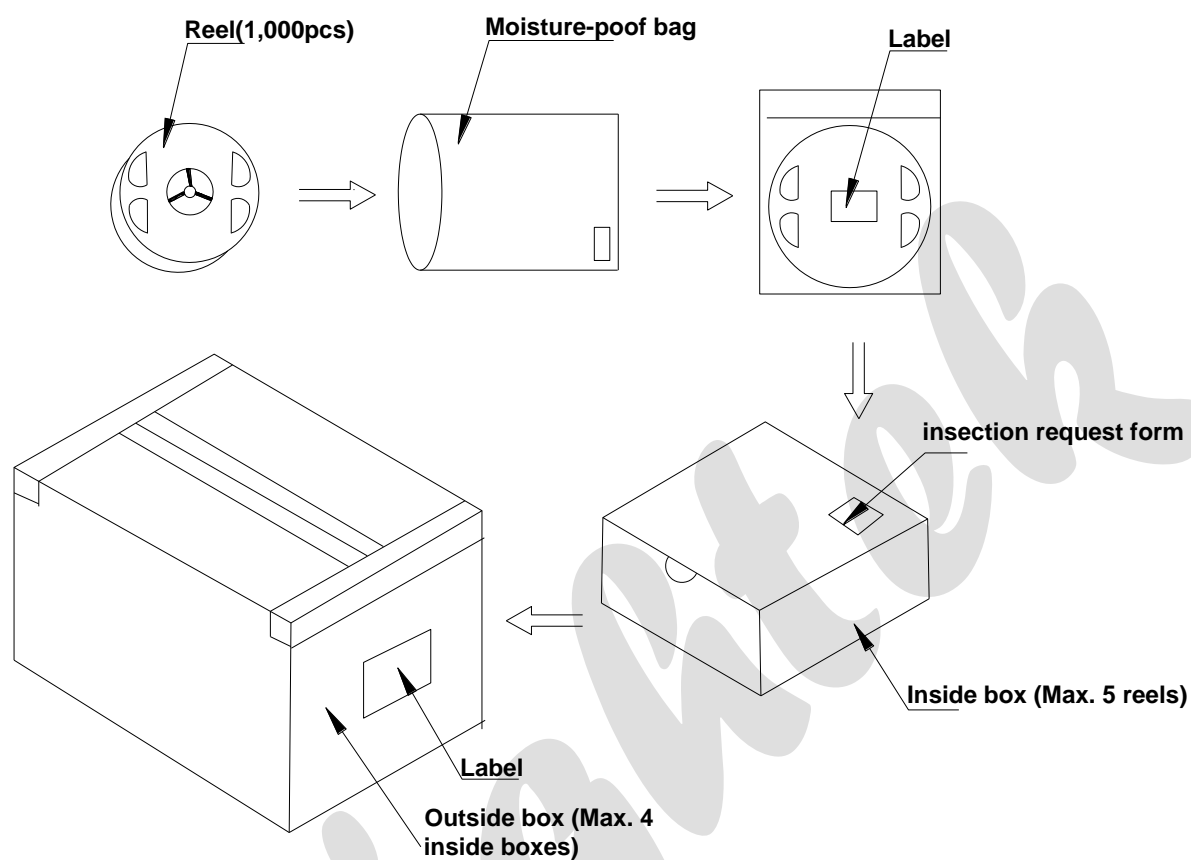

Reeled product (max.1,000 ) is packed in a sealed moisture-proof bag. Five bags are packed in an inner box (size: about 260 X 230 X 100 mm) and four inner boxes are in an outer box (size: about 480 X 275 X 215 mm). On the label of moisture-proof bag, there should be the information of Part No., Lot No. and quantity number; also the total quantity number should be on inspection request form on outer box.

## Precautions

### 1. Abnormal situation caused by improper setting of collet

To choose the right collet is the key issue in improving the product's quality. LED is different from other electronic components, which is not only about electrical output but also for optical output. This characteristic made LED more fragile in the process of SMT. If the collet's lowering down height is not well set, it will bring damage to the gold wire at the time of collet's picking up and loading which will cause the LED fail to light up, light up now and then or other quality problems.

### 2. How to choose the collet

During SMT, please choose the collet that has larger outer diameter than the lighting area of lens, in case that improper position of collet will damage the gold wire inside the LED. Different collets fit for different products, please refer to the following pictures cross out.

**Outer diameter of collet should be larger than the lighting area**

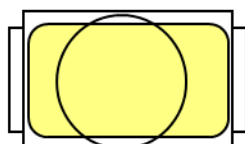

Picture 1 (✓)

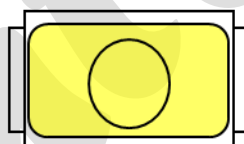

Picture 2 (X)

### 3. Other points for attention

- No pressure should be exerted to the epoxy shell of the SMD under high temperature.
- Do not scratch or wipe the lens since the lens and gold wire inside are rather fragile and cross out easy to break.
- CLED should be used as soon as possible when being taken out of the original package, and should be stored in anti-moisture and anti-ESD package.

### 4. This usage and handling instruction is only for your reference.